

## Autopower Roll Bars and Roll Cages



Autopower is the leader in quality roll bars and cages. Their high standards of workmanship are unsurpassed. Autopower was the first manufacturer of roll bars to be licensed and certified by the SCCA. Roll bars include backup plates and grade 5 mounting hardware. Autopower roll bars are constructed of 1.75 O.D. x .120 wall DOM (Drawn Over Mandrel) mild steel tubing. Roll cages are constructed of 1.50 O.D. x .120 wall or 1.75 O.D. x .120 wall DOM mild steel tubing, depending on car weight.

**Note:** The SCCA now requires DOM tubing in all cars regardless of vehicle weight and racing class.

### Important Information About Ordering Your Roll Bar or Roll Cage

- Allow 4 to 8 weeks for delivery depending upon the time of year.
- Don't be disappointed - ORDER EARLY!
- Bars and cages are shipped freight collect directly from the factory via truck freight.
- When ordering, give us the year, make, model, racing class and specify whether or not your car has a factory installed sunroof.
- Give us a call if you have ANY questions!

ROLL BARS

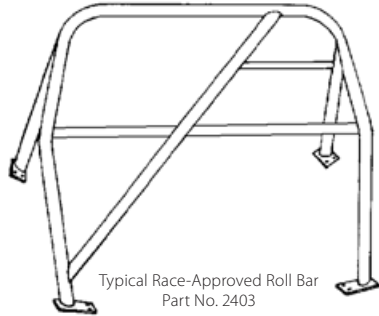

Typical Race-Approved Roll Bar  
Part No. 2403

**Race-Approved Roll Bar** This bar has a diagonal brace, a horizontal seat back brace, and a small restraint bar behind the driver's seat. The cross braces are normally welded in place; however, bolt-in options are available to allow rear seat use off the track; see below.

**Race-Approved Roll Bar, 1.75" O.D. DOM**  
Part No. 2403-1.75-DOM ..... \$669.00  
*Note: SCCA requires a full cage in all road racing classes.*

**Bolt-In Cross Brace Option** This option must be ordered at the same time as your roll bar.

**Bolt-In Cross Brace Option** ..... Part No. 2408 ..... \$109.99  
*Replaces the welded braces included with roll bar; can be removed when not racing to allow use of the back seat.*



Typical Complete U-Weld Roll Cage Kit  
Part No. 2405

**Complete U-Weld Roll Cage Kit** Includes DOM race-approved roll bar, 2 forward support braces, top windshield cross bar, under-dash cross bar, left and right door guards, mounting plates, and hardware. Parts are precision cut and bent for each individual model; however, final fitting and welding is required.

**U-Weld Roll Cage Kit, 1.5" Tubing for cars up to 3000 lbs.**  
Part No. 2405-1.50-DOM ..... \$1,039.00  
**U-Weld Roll Cage Kit, 1.75" Tubing for cars up to 4000 lbs.**  
Part No. 2405-1.75-DOM ..... \$1,039.00

**U-Weld Front Cage Kit** Add this kit to an existing Autopower Race-Approved Roll Bar to make a legal 6-point roll cage. Tube size will be determined by Autopower when you place your order. Kit includes 4 top corner gussets, under-dash bar, 4 door bars, forward support braces, a top windshield cross tube, and all necessary hardware.

**U-Weld Front Cage Kit** ..... Part No. 2413-001 . \$529.00

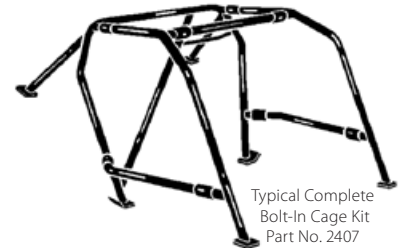

Typical Complete Bolt-In Cage Kit  
Part No. 2407

**Complete Bolt-In Cage Kit** These six-point cage kits include a race-approved roll bar, double door bars, sleeves, backing plates, and hardware. Requires a 3/8" drill and hand tools for installation.

**Bolt-In Cage Kit, 1.5" Tubing for cars up to 3000 lbs.**  
Part No. 2407-1.50-DOM ..... \$1,179.00  
**Bolt-In Cage Kit, 1.75" Tubing for cars up to 4000 lbs.**  
Part No. 2407-1.75-DOM ..... \$1,179.00

## Roll Bar Padding



The padding is easily slipped onto any removable brace. Simply slit it along the thin side to snap it over a permanently installed bar. Hold it in place with racer's tape or cable ties. The one-size-fits-most padding fits 1.50" to 1.75" diameter bars. It can be made to fit smaller bars with a little trimming. Available in Black, Blue, Red, Yellow, or Grey. Sold in 3 foot lengths.

**Roll Bar Padding** ..... Part No. 2390-Color ..... \$4.99

### High-Density Roll Bar Padding

This basic padding has an offset hole to fit where clearance is tight on one side and to position the padding where it will do the most good. The thin side is about 1/2" thick, and the thick side is about 1" thick.



**FIA 8857-2001 Type A Roll Bar Padding** This super-rigid padding is similar to the SFI-rated padding (above right), but it carries FIA approval. It is designed for use wherever your helmet can contact the roll bar, so the C-shape profile covers just **one side** of the bar (order 2 pieces if you want full coverage around the bar). A self-adhesive lining makes installation easy. Two sizes are available to fit bars from 1.12" to 1.5", and from 1.625" to 2" OD. Available in Black only. Sold in 3 foot lengths.

**FIA-Approved Roll Bar Padding, 1.125" - 1.5" bars** ..... Part No. 2398 ..... \$23.99  
**FIA-Approved Roll Bar Padding, 1.625" - 1.75" bars** ..... Part No. 2399 ..... \$23.99



**Note:**  
SFI 45.1 padding is C-shaped to cover only the one side of the bar that your helmet may contact

**SFI 45.1 Rated Roll Bar Padding** This super-rigid padding is strongly recommended by the SCCA. It is designed for use wherever your helmet can contact the roll bar, so the C-shape profile covers just **one side** of the bar (order 2 pieces if you want full coverage around the bar). A self-adhesive lining makes installation easy. Two sizes are available to fit bars from 1.12" to 1.5", and from 1.625" to 2" OD. Available in Black, Blue, or Red. Sold in 3 foot lengths.

**SFI Rated Roll Bar Padding, 1.12" - 1.5" bars** ..... Part No. 2391-Color ..... \$18.99  
**SFI Rated Roll Bar Padding, 1.625" - 2" bars** ..... Part No. 2395-Color ..... \$18.99

**SFI 45.1 Dual-Density Padding** Get the best of both types of roll bar padding! A base layer of SFI 45.1 roll bar padding is covered by a removable layer of high-density comfort padding to absorb more minor impacts. Use just the base layer around your helmet, and both layers where your arms are more likely to hit the bar. As with the SFI 45.1 padding at left, the C-shape profile covers just **one side** of the bar (order 2 pieces if you want full coverage around the bar). Fits 1.5" to 2" diameter bars. Black only. Sold in 3 foot lengths.

**SFI Rated Dual-Density Padding** ..... Part No. 2397-Black ..... \$36.99

## Clamp-On Roll Bar Mounts



**Steering Wheel Hook** This black anodized aluminum hook clamps onto your roll bar to hang your removable steering wheel when you get in and out of the car. It's also a handy place to hang your helmet between sessions. Available in two sizes to fit 1.50" or 1.75" roll bar tubing.

**Wheel Hook for 1.50" roll bar**  
Part No. LA22577 ..... \$19.99  
**Wheel Hook for 1.75" roll bar**  
Part No. LA22576 ..... \$19.99



**Universal Roll Bar Brackets** These aluminum clamp-on brackets have two #8-32 SAE screws spaced 1" center-to-center to mount panels, mirrors, almost anything to your roll bar. Holds items 3/4" from bar. Available in two sizes, 1.50" and 1.75". Sold individually.

**Universal Bracket for 1.50" bar**  
Part No. 22757 ..... \$19.99  
**Universal Bracket for 1.75" bar**  
Part No. 22755 ..... \$19.99



**Clamp-On Bracket Reducers** Use these clever aluminum adapter sleeves to reduce 1 3/4" ID clamp-on brackets to fit 1 1/4", 1 1/2", or 1 3/8" OD tubing. Just install your clamp-on accessory right over the reducer. The 1/4" wide U-channel groove in the reducer prevents the bracket from slipping off. Sold in pairs; one pair fits one clamp-on bracket.

**Clamp-On Reducers, pair (for one bracket)**  
Part No. 1318-025-Size ..... \$11.99